



## FEATURES

- High output to size/weight ratio. Size and output capabilities allow it to be used in the widest variety of venues.
- Exceptional pattern control due to symmetrical design, large horn(s) and spaced woofers.
- Incorporates latest EAW technologies including CSA and Focusing for improved mid and high frequency transient response.
- Fully compatible with KF760 and KF730 systems.

## DESCRIPTION

The KF740 line array system is optimized for the widest possible range of touring and installation applications. With output capabilities resembling the much larger KF760 and a footprint and weight similar to the diminutive KF730, the KF740 is the ideal solution for a wide variety of applications including touring sound, corporate A/V, sports arenas, houses of worship, performing arts centers, hotel ballrooms and live clubs.

The KF740 delivers the premium, high output, 3-way performance that is the hallmark of the KF Series in an extremely compact and easy-to-use package. Dual 62mm voice coil HF compression drivers and dual 8-in Concentric Summation Array (CSA) loaded MF transducers are integrated through a common horn that occupies the entire face of the enclosure. The astounding pattern control offered by this configuration is extended even further (down to 160 Hz) as the MF devices are transitioned to a spaced array of four 2.5-in voice coil 10-in woofers. The pair of LF devices integrated within the MF/HF horn combined with the pair of side-mounted devices provides as much as 18 dB of off-axis rejection. The EAW Focused processing delivered via the UX8800 DSP precisely transitions from one system subsection to another while maintaining nearly perfect 90 degree control.

A full KF740 array provides seamless coverage from directly below the array to hundreds of feet in front. The vertical output can be tailored to match the requirements of any space by varying the splay at the rear of the enclosures as directed by EAW Resolution software. The resultant configuration repeatedly produces a continuous, coherent wave front of extended-range, high resolution audio over the entire defined coverage area. Broadly applicable line sources can be constructed solely of KF740 modules. The versatile KF740 can also be integrated above KF730 modules or beneath KF760 modules to extend the reach of the range to any application imaginable. The impressive low frequency output and extension of the KF740 can be even further enhanced by the use of the complementary SB1002 flying subwoofer.

The truck-pack friendly KF740 is assembled in the USA with unrivaled construction details including: cabinet grade exterior Baltic birch plywood enclosure; wear resistant textured coating; powder-coated steel grille; extruded structural aluminum rigging; precision quick release rigging pins; Neutrik NL8 connectors; heavy duty bar handles; cast aluminum side handholds; and accessory caster pallets, flybars and adapter bars (the AB7674-73 attaches the KF740 or KF730 to the KF760, the AB7473 attaches the KF730 to the KF740).

## 3-WAY FULL-RANGE LOUDSPEAKER

See *NOTES TABULAR DATA* for details

### CONFIGURATION

#### Subsystem:

	<b>Transducer</b>	<b>Loading</b>
LF	4x 10-in cone	Sealed, Phase Aligned
MF	2x 8-in cone	Horn-loaded w/CSA™ Aperture
HF	2x 1.4-in exit, 2.5-in voice coil compression driver	Horn-loaded

#### Operating Mode:

	<b>Amplifier Channels</b>	<b>External Signal Processing</b>
	Tri-amp LF, MF, HF	DSP w/3-way filters

### PERFORMANCE

**Operating Range:** 50 Hz to 20 kHz

#### Nominal Beamwidth:

Horz 90°

Vert 12°

#### Axial Sensitivity (whole space SPL):

LF	93 dB	50 Hz to 345 kHz
MF	107 dB	255 Hz to 1373 Hz
HF	110 dB	1220 Hz to 20 kHz

#### Input Impedance (ohms):

	<b>Nominal</b>	<b>Minimum</b>
LF	2x 8 (4)	4 @ 214 Hz
MF	8	8 @ 1372 Hz
HF	8	6.7 @ 5620 Hz

**High Pass Filter:** High Pass=>40 Hz, 12 dB/octave Butterworth

#### Accelerated Life Test:

LF	74.8 V	2x 700 W @ 8 ohm (1400 W @ 4 ohm)
MF	70.7 V	625 W @ 8 ohm
HF	40 V	200 W @ 8 ohm

#### Calculated Axial Output Limit (whole space SPL):

	<b>Average</b>	<b>Peak</b>
LF	124 dB	130 dB
MF	135 dB	141 dB
HF	133 dB	139 dB

### PHYSICAL

Dimensions (H x W x D):	13" x 40.1" x 17.56" 330.2mm x 1018.5mm x 446.0mm
Net Weight:	107.2 lbs (48.6 kg)
Shipping Weight	120 lbs (54.4 kg)

### ORDERING DATA

<b>Description</b>	<b>Part Number</b>
EAW KF740 3-way Full-Range Loudspeaker Black	0033033

#### Optional Accessories

KF740 flybar, FB174	0033126
KF740 pallet, PLT74K	0033466
KF740/KF730 to KF760 adapter bar, AB7674-73	2034117
KF740 to KF730 adapter bar, AB7473	0032870

## ENCLOSURE

Material	Exterior-grade Baltic birch plywood
Finish	Wear resistant textured black paint
Grille	Powder-coated perforated steel

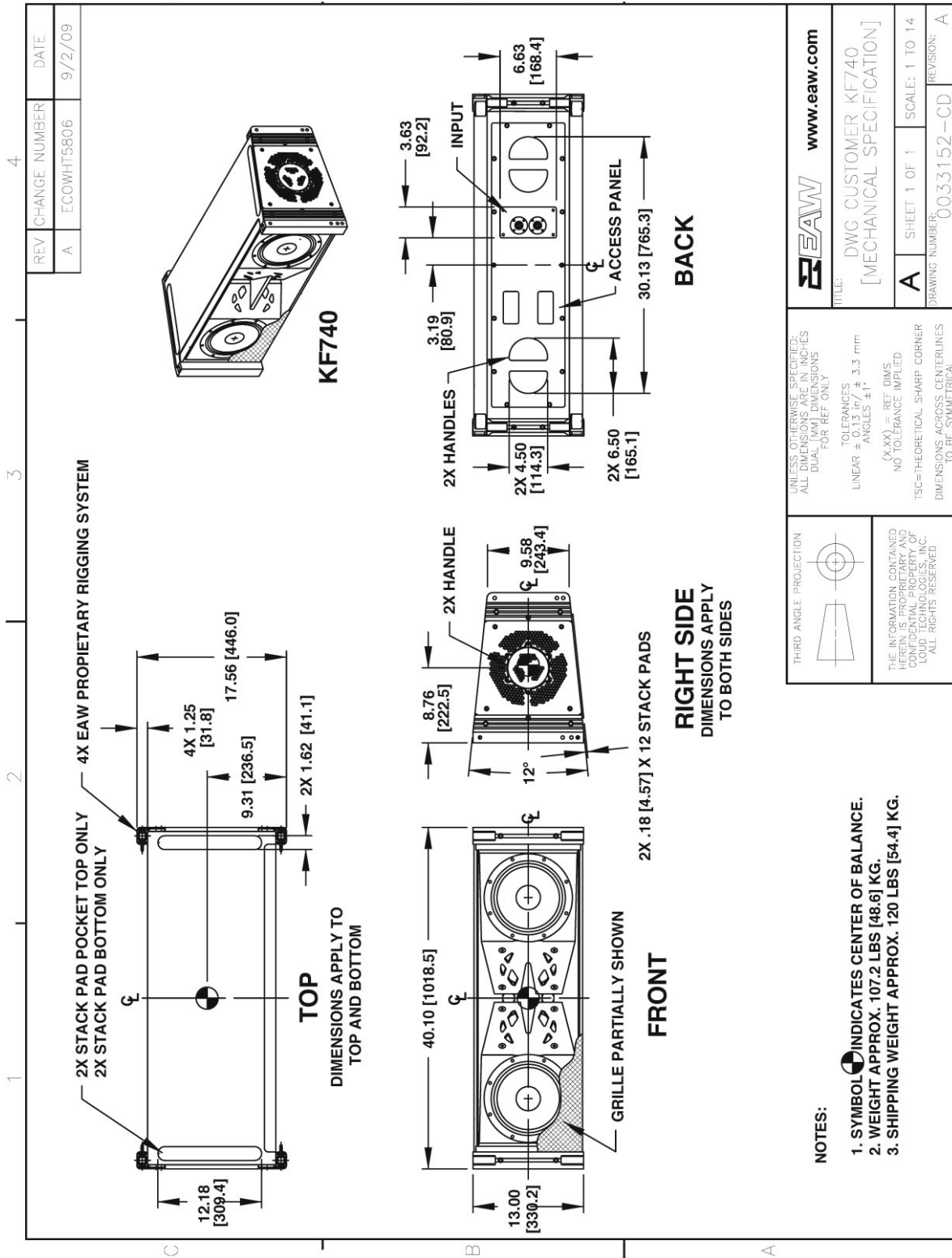

**NOTE:** This drawing has been reduced. Do not scale.

**PERFORMANCE DATA**

See NOTES GRAPHIC DATA for details

**Frequency Response: Multi-amplified**

LF = green, MF = orange, HF = black, LF/MF/HF = blue

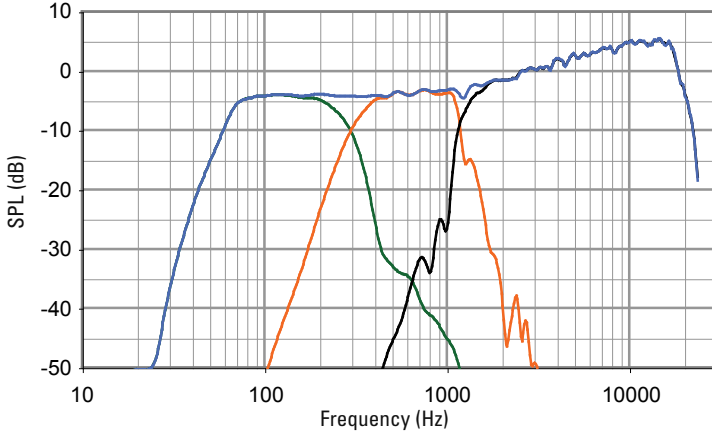

**Frequency Response: Unprocessed**

LF = green, MF = orange, HF = black

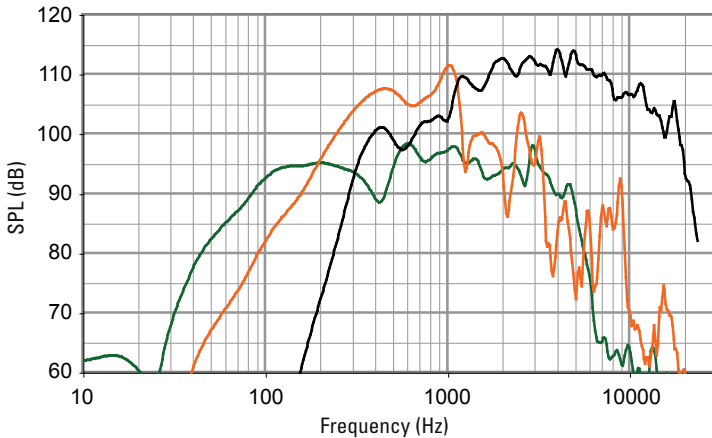

**Phase Response: Linearity**

Complete = blue

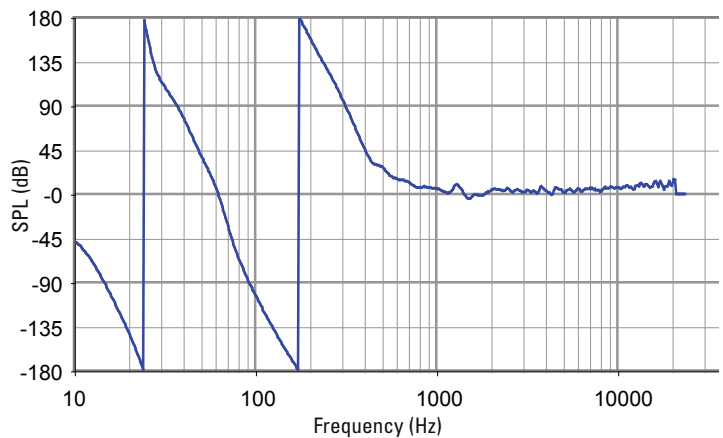

**Impedance Magnitude**

LF = green, MF = orange, HF = black

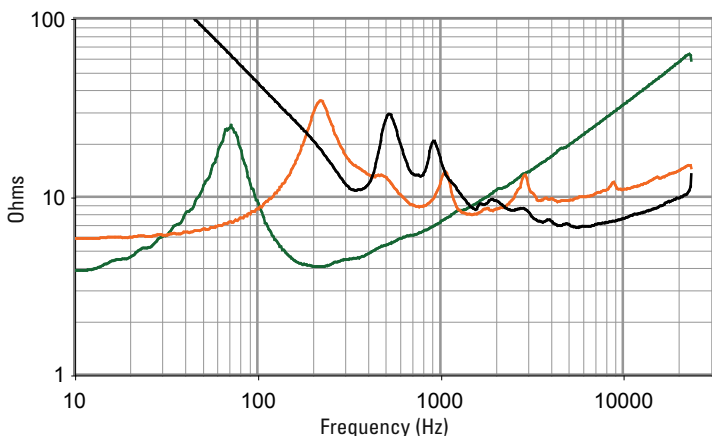

**Beamwidth (-6 dB SPL Points)**

Horizontal = orange Vertical = black

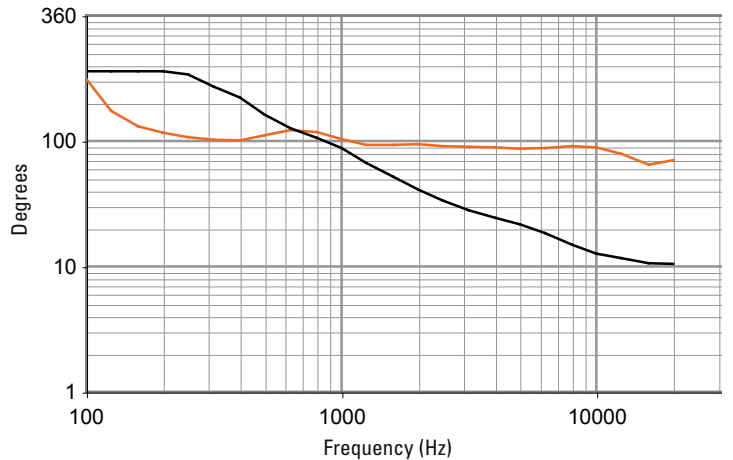

**HORIZONTAL POLAR DATA**

See *NOTES GRAPHIC DATA* for details

100 Hz  
125 Hz  
160 Hz  
200 Hz

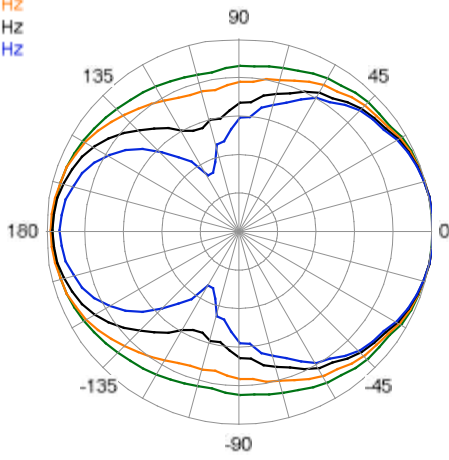

1600 Hz  
2000 Hz  
2500 Hz  
3150 Hz

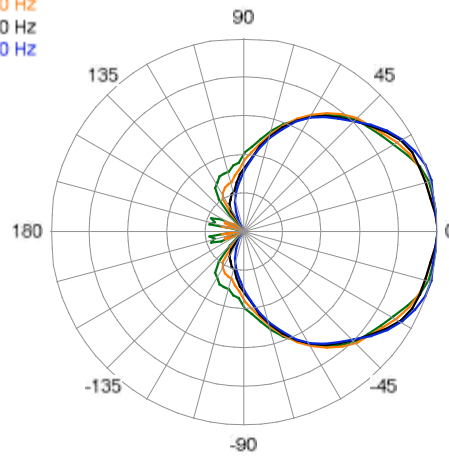

250 Hz  
315 Hz  
400 Hz  
500 Hz

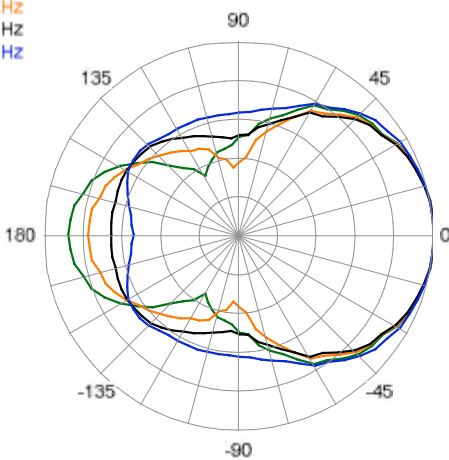

4000 Hz  
5000 Hz  
6300 Hz  
8000 Hz

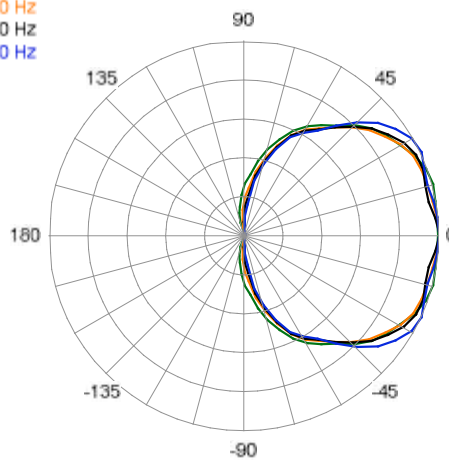

630 Hz  
800 Hz  
1000 Hz  
1250 Hz

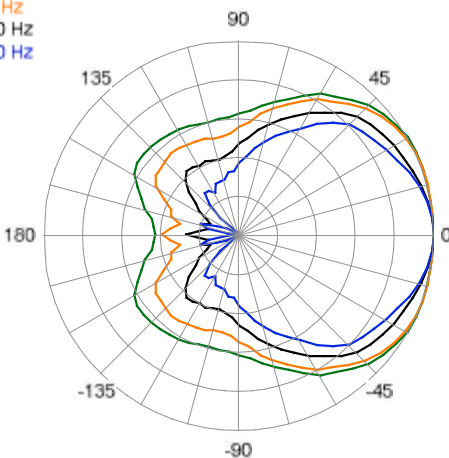

10000 Hz  
12500 Hz  
16000 Hz

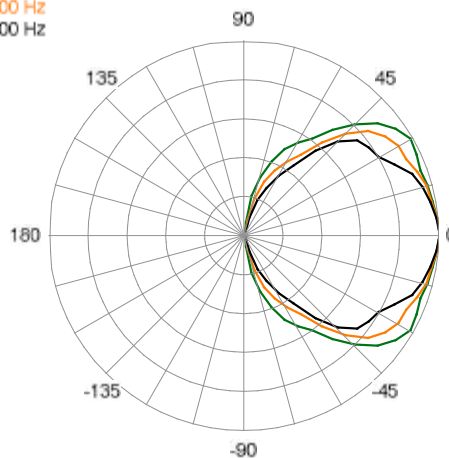

**VERTICAL POLAR DATA**

See *NOTES GRAPHIC DATA* for details

100 Hz  
125 Hz  
160 Hz  
200 Hz

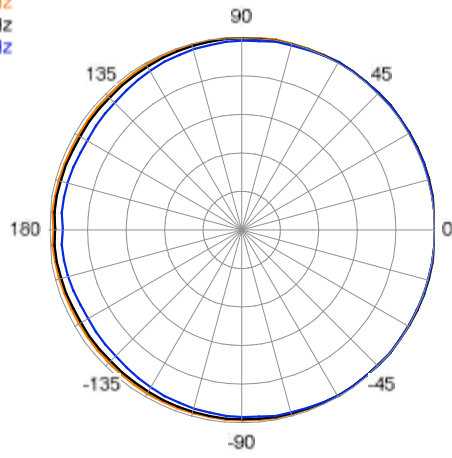

1600 Hz  
2000 Hz  
2500 Hz  
3150 Hz

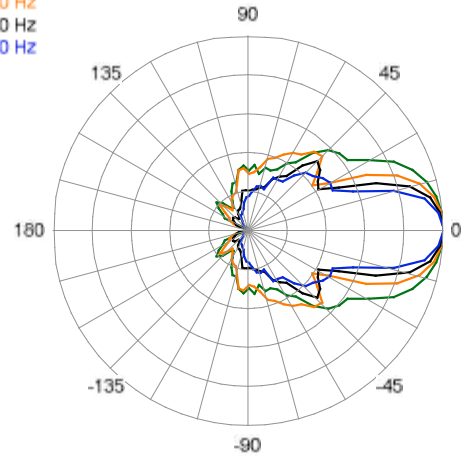

250 Hz  
315 Hz  
400 Hz  
500 Hz

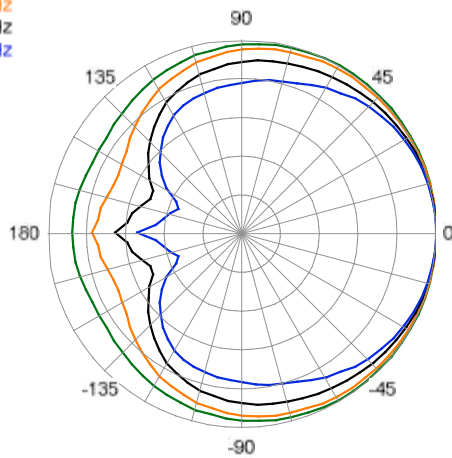

4000 Hz  
5000 Hz  
6300 Hz  
8000 Hz

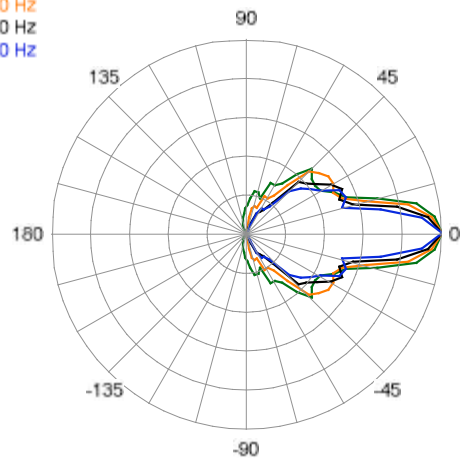

630 Hz  
800 Hz  
1000 Hz  
1250 Hz

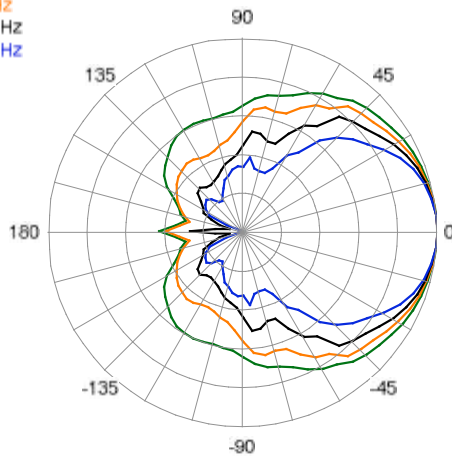

10000 Hz  
12500 Hz  
16000 Hz

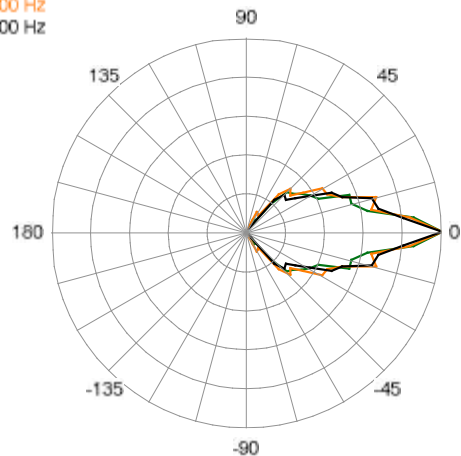

## INPUT PANEL

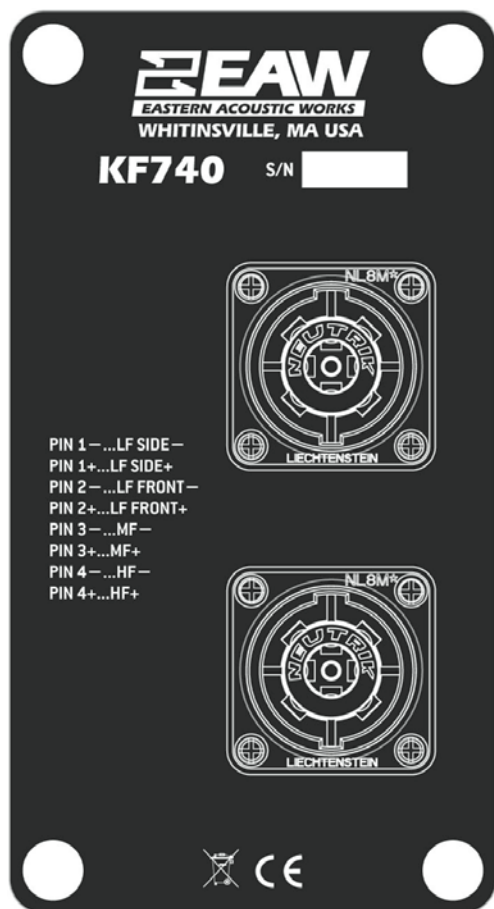

## SIGNAL DIAGRAM

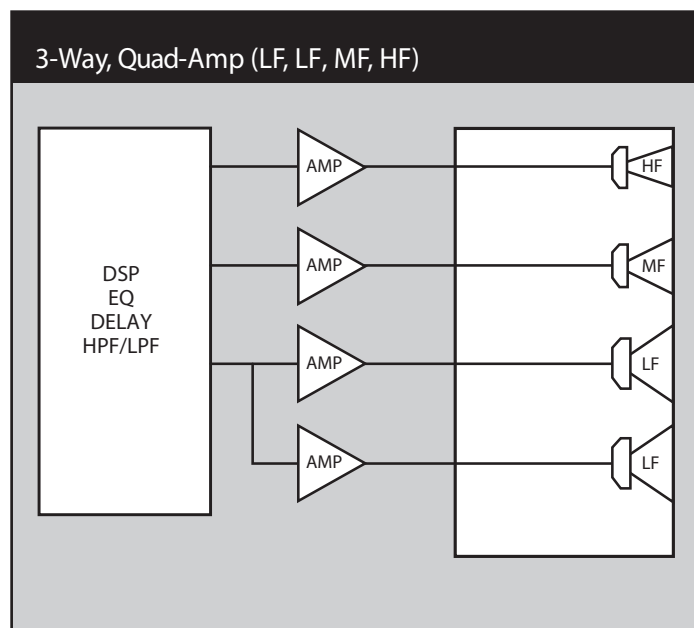

## LEGEND

- DSP:** EAW UX8800 Digital Signal Processor.
- HPF:** High Pass Filter for crossover or Recommended High Pass Filter.
- LPF:** Low Pass Filter for crossover.
- LF/MF/HF:** Low Frequency / Mid Frequency / High Frequency.
- AMP:** User-supplied Power Amplifier.

## NOTES

### TABULAR DATA

1. **Measurement/Data Processing Systems:** Primary - FChart: proprietary EAW software; Secondary - Brüel & Kjær 2012.
2. **Microphone Systems:** Earthworks M30; Brüel & Kjær 4133
3. **Measurements:** Dual channel FFT; length: 32 768 samples; sample rate: 48 kHz; logarithmic sine wave sweep.
4. **Measurement System Qualification** (includes all uncertainties): SPL: accuracy +/-0.2 dB @ 1 kHz, precision +/-0.5 dB 20 Hz to 20 kHz, resolution 0.05 dB; Frequency: accuracy +/-1 %, precision +/-0.5 Hz, resolution the larger of 1.5 Hz or 1/48 octave; Time: accuracy +/-10.4 µs, precision +/-0.5 µs, resolution 10.4 µs; Angular: accuracy +/-1°, precision +/-0.5°, resolution 0.5°.
5. **Environment:** Measurements time-windowed and processed to eliminate room effects, approximating an anechoic environment. Data processed as anechoic or fractional space, as noted.
6. **Measurement Distance:** 7.46 m. Acoustic responses represent complex summation of the subsystems at 20 m. SPL is referenced to other distances using the Inverse Square Law.
7. **Enclosure Orientation:** For beamwidth and polar specifications, as shown in Mechanical Specification drawing.
8. **Volts:** Measured rms value of the test signal.
9. **Watts:** Per audio industry practice, "loudspeaker watts" are calculated as voltage squared divided by rated nominal impedance. Thus, these are not True Watt units of energy as defined by International Standard.
10. **SPL:** (Sound Pressure Level) Equivalent to the average level of a signal referenced to 0 dB SPL = 20 microPascals.
11. **Subsystem:** This lists the transducer(s) and their acoustic loading for each passband. Sub = Subwoofer, LF = Low Frequency, MF = Mid Frequency, HF = High Frequency.
12. **Operating Mode:** User selectable configurations. Between system elements, a comma (,) = separate amplifier channels; a slash (/) = single amplifier channel. DSP = Digital Signal Processor.  
IMPORTANT: To achieve the specified performance, the listed external signal processing must be used with EAW-provided settings.
13. **Operating Range:** Range where the processed Frequency Response stays within -10 dB SPL of the power averaged SPL within this range; measured on the geometric axis. Narrow band dips are excepted.
14. **Nominal Beamwidth:** Design angle for the -6 dB SPL points, referenced to 0 dB SPL as the highest level.
15. **Axial Sensitivity:** Power averaged SPL over the Operating Range with an input voltage that would produce 1 W at the nominal impedance; measured with no external processing on the geometric axis, referenced to 1 m.
16. **Nominal Impedance:** Selected 4, 8, or 16 ohm resistance such that the minimum impedance point is no more than 20% below this resistance over the Operating Range.
17. **Accelerated Life Test:** Maximum test input voltage applied with an EIA-426B defined spectrum; measured with recommended signal processing and Recommended Protection Filter.
18. **Calculated Axial Output Limit:** Highest average and peak SPLs possible during the Accelerated Life Test. The Peak SPL represents the 2:1 (6 dB) crest factor of the Life Test signal.
19. **High Pass Filter:** This helps protect the loudspeaker from excessive input signal levels at frequencies below the Operating Range.

### GRAPHIC DATA

1. **Resolution:** To remove insignificant fine details, 1/12 octave cepstral smoothing was applied to acoustic frequency responses and 1/3 octave cepstral smoothing was applied to the beamwidth and impedance data. Other graphs are plotted using raw data.
2. **Frequency Responses:** Variation in acoustic output level with frequency for a constant input signal. Processed: normalized to 0 dB SPL. Unprocessed inputs: 2 V (4 ohm nominal impedance), 2.83 V (8 ohm nominal impedance), or 4 V (16 ohm nominal impedance) referenced to a distance of 1 m.
3. **Processor Response:** The variation in output level with frequency for a constant input signal of 0.775 V = 0 dB reference.
4. **Beamwidth:** Average angle for each 1/3 octave frequency band where, starting from the rear of the loudspeaker, the output first reaches -6 dB SPL referenced to 0 dB SPL as the highest level. This method means the output may drop below -6 dB SPL within the beamwidth angle.
5. **Impedance:** Variation in impedance magnitude, in ohms, with frequency without regard to voltage/current phase. This means the impedance values may not be used to calculate True Watts (see 9 above).
6. **Polar Data:** Horizontal and vertical polar responses for each 1/3 octave frequency band 100 Hz to 16 kHz or Operating Range.

